

**CASE *ii***

**LX700 LOADERS**



# LOADER FEATURES

- ▶ **The optional Soft Ride feature** plugs directly into the Central Hydraulic Valve and enhances load control over uneven terrain.

The LX700 Series loader, matched with the right Case IH tractor, is the perfect system to improve both ease of operation and operator comfort. The upgraded features on the LX700 Series are engineered to take your loader operations to new levels of productivity.

Visibility is key when working with any loader. The LX700 Series provides unmatched visibility for the operator. The extra strong, double-U arm profile of the booms and lower cross tubing provides clear views to the attachment, load, and front tires. Greater visibility leads to greater productivity through enhanced implement control. The built-in strength of the loader design means a longer loader life and a better return on your investment.



- ▲ **Quick Lock** mounting system is quick and easy. The spring-loaded design keeps the pins with the loader—no pins or parts to search for when attaching the loader. Safety mechanisms are built-in for simplicity and dependability.



- ▲ **The new Central Hydraulic Valve** is protected by the cross tube and a cover reducing damage to hoses, tubes, and accumulators. The valve allows all hydraulic hoses to connect at one point.



- ▲ **Short-stroke, large-diameter lift cylinders** offer generous breakout forces and reduced cycle times. Cylinder design and placement create maximum clearance for large front tires.



- ▲ **Maintenance is a snap** with easy access grease points on the outside of the loader. Snap covers protect all grease zerks from contaminants and keep excess grease off of your tractor and loader during powerwashing.

# LOADER ATTACHMENTS

With a large line of attachments, your LX700 Series loader truly becomes the best multi-tool for your operation. Case IH has the attachment to get all your chores done—and done quicker.

Attachment to the loader is simple and performed without leaving the operator station. Roll the tool carrier to the dump position, raise the loader under the beam to the visible attachment hooks, cycle to the fill position, and the pins lock automatically—no need to get out and lock the pins.

## 70+ Attachment Choices



Model	Size	LX720	LX730	LX740	LX750	LX760	LX770	LX780
Standard Material Buckets	63" - 102"	✓	✓	✓	✓	✓	✓	✓
Heavy-Duty Material Buckets	73" - 102"	✓	✓	✓	✓	✓	✓	✓
Heavy-Duty Material Buckets w/Teeth	63" - 83"	✓	✓	✓	✓	✓	✓	✓
Light High Capacity Material Bucket	79" & 87"	✓	✓	✓	✓	✓	✓	✓
Standard High Capacity Material Bucket	79" - 102"	✓	✓	✓	✓	✓	✓	✓
High-Tipping Bucket	91"	✓	✓	✓	✓	✓	✓	✓
Heavy-Duty Grading Buckets	85"	✓	✓	✓	✓	✓	✓	✓
Manure Tine	59" - 90"	✓	✓	✓	✓	✓	✓	✓
Multi-Use Fork	59" & 79"	✓	✓	✓	✓	✓	✓	✓
Rock Fork (Stone Bucket)	59" & 79"	✓	✓	✓	✓	✓	✓	✓
Pallet Fork	38" & 47"	✓	✓	✓	✓	✓	✓	✓
Pallet Fork Attachment	Log Grab & Bale Spike	✓	✓	✓	✓	✓	✓	✓
Silage King Bucket and Grapple (Multibenne)	59" - 98"	✓	✓	✓	✓	✓	✓	✓
Heavy-Duty Silage King Bucket and Grapple (Multigrab Heavy-Duty)	63" - 79"				✓	✓	✓	✓
Silage King Fork and Grapple (Silograb)	51" - 98"	✓	✓	✓	✓	✓	✓	✓
Silage Block Cutter (SILOCUT)	44" - 75"		✓	✓	✓	✓	✓	✓
Heavy-Duty Bale Grip (FLEXIX RIP)	63" & 79"	✓	✓	✓	✓	✓	✓	✓
Universal Bale Grip (UNIGRIP)	51" & 63"	✓	✓	✓	✓	✓	✓	✓
Combo Bale & Pallet Fork (FLEXIBAL)	71"	✓	✓	✓	✓	✓	✓	✓
Heavy-Duty Round or Square Plastic Wrapped Bale Grip	Bale Size 23" - 80"			✓	✓	✓	✓	✓
Bale Handler			✓	✓	✓	✓	✓	✓
Bale Split Attachment (SILOSPLIT)	STD & HD	✓	✓	✓	✓	✓	✓	✓
Bale Spike		✓	✓	✓	✓	✓	✓	✓
Round and Large Square Bale Fork	2 Tines	✓	✓	✓	✓	✓	✓	✓
Heavy-Duty Buckets and Grapple with Tines (Maxi Grapple MK2 T - grapple assemble w/bucket and tines)	83" - 102"	✓	✓	✓	✓	✓	✓	✓
Heavy-Duty Bucket (Maxi Grapple MK2 - bucket only, no tines)	83" - 102"	✓	✓	✓	✓	✓	✓	✓
Heavy-Duty Bucket with Grapple and Extended Floor (Maxi Grapple MK2 -grapple assemble w/extended bucket floor)	83" - 102"	✓	✓	✓	✓	✓	✓	✓
Heavy-Duty Bucket (Maxi Grapple MK2 - bucket only)	83" - 102"	✓	✓	✓	✓	✓	✓	✓
Square Bale Fork	55" & 75"	✓	✓	✓	✓	✓	✓	✓

Note: Attachment sizes vary depending on tractor capacities — talk to your Case IH dealer about proper matching.

# SPECIFICATIONS



LX SERIES LOADER MODEL	LX720		LX730			LX740		LX750	LX760	LX770	LX780
Tractor Family	JXC	JX	JXC	JX	JXU	JXU	Maxxum PRO	Maxxum PRO	Puma	Puma	Magnum
Tractor Model	1060-1095	55-70	1085-1095	75-95	1080-1100	1080-1100	110, 120, 130	115, 125, 140	165-180	165-210	215-305
Lift Capacity @ Max. Height* - lbs. (kg)	2,100 (953)	2,100 (953)	2,500 (1134)	2,500 (1134)	2,500 (1134)	3,200 (1451)	3,370 (1529)	3,700 (1678)	4,300 (1950)	4,900 (2223)	5,250 (2381)
Lift Capacity @ Max. Height @ Pins - lbs. (kg)	3,300 (1497)	3,300 (1497)	3,850 (1746)	3,850 (1746)	3,850 (1746)	4,850 (2200)	5,080 (2304)	5,350 (2427)	6,050 (2744)	5,450 (2472)	5,950 (2699)
Breakout Force* - lbs. (kg)	2,650 (1202)	2,650 (1202)	3,100 (1406)	3,100 (1406)	3,100 (1406)	3,850 (1746)	4,060 (1842)	4,400 (1996)	5,000 (2268)	5,800 (2631)	7,000 (3175)
A - Max. Lift Height - in. (m)	124 (3.15)	125 (3.17)	133 (3.37)	136 (3.45)	136 (3.45)	144 (3.65)	145 (3.68)	154 (3.91)	169 (4.29)	178 (4.52)	187 (4.74)
B - Max. Lift Height Under Level bucket - in. (m)	112 (2.84)	113 (2.87)	121 (3.07)	124 (3.14)	124 (3.07)	132 (3.35)	133 (3.37)	142 (3.60)	157 (3.99)	166 (4.22)	175 (4.44)
C - Clearance w/Bucket Dumped - in. (m)	86 (2.18)	87 (2.21)	96 (2.43)	98 (2.43)	98 (2.43)	106 (2.69)	107 (2.71)	116 (2.94)	131 (3.33)	140 (3.56)	150 (3.81)
D - Reach @ Max. Lift Height - in. (m)	28 (0.71)	43 (1.09)	25 (0.63)	36 (.91)	33 (0.83)	34 (0.86)	31 (0.78)	31 (0.78)	29 (0.74)	29 (0.74)	7 (0.177)
E - Max. Dump Angle	64°	67°	55°	58°	57°	59°	63°	57°	55°	55°	57°
F - Reach @ Ground Line - in. (m)	86 (2.18)	86 (2.18)	93 (2.36)	88 (2.23)	90 (2.28)	98 (2.48)	92 (2.33)	100 (2.54)	104 (2.64)	113 (2.87)	109 (2.76)
G - Bucket Rollback Angle	45°	41°	50°	45°	46°	46°	43°	45°	41°	43°	38°
H - Digging Depth - in. (mm)	7 (179)	8 (203)	7 (179)	5 (127)	5 (127)	7 (179)	8 (203)	8 (203)	4 (100)	6 (152)	6 (152)
Optional Mechanical Leveling System	Yes	Yes	Yes	Yes	Yes	Yes	Yes	Yes	Yes	Yes	Yes
Raising Time - Seconds	3.3	3.3	4.1	4.1	4.1	5.4	3.1	3.5	3.5	4.6	3.4
Lowering Time - Seconds	2.0	2.0	2.8	2.8	2.8	4.1	2.3	2.7	2.8	3.7	2.7
Bucket Dump Time - Seconds	3.5	3.5	3.5	3.5	3.5	4.6	2.6	2.6	2.4	2.9	1.8
Bucket Rollback Time - Seconds	2.4	2.4	2.4	2.4	2.4	3.4	2.0	2.0	1.9	2.9	1.8
Approx. Weight - lbs. (kg) - w/o bucket	960 (435)	960 (435)	990 (449)	990 (449)	990 (449)	1,135 (515)	1,135 (515)	1,220 (553)	1,385 (628)	1,675 (760)	1,780 (807)
Mounting time - Boom to Tractor	90 seconds	90 seconds	90 seconds	90 seconds	90 seconds	90 seconds	90 seconds	90 seconds	90 seconds	90 seconds	90 seconds
Mounting time - Implement to Loader	10 seconds	10 seconds	10 seconds	10 seconds	10 seconds	10 seconds	10 seconds	10 seconds	10 seconds	10 seconds	10 seconds

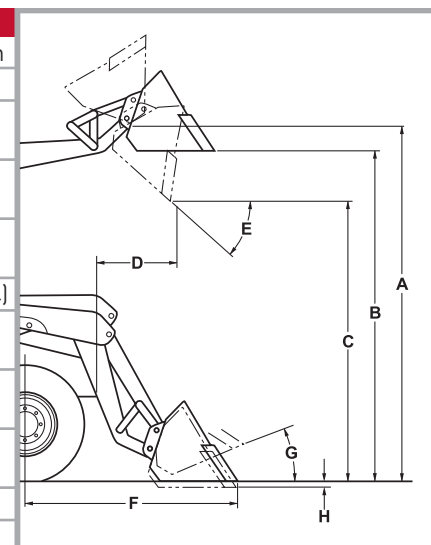

\* Measured at 31.5 inches (800 mm) ahead of pin.  
Note: Loader specifications may vary based on tractor model, hydraulic system, tire size, etc.



**Safety Never Hurts!™** Always read the Operator's Manual before operating any equipment. Inspect equipment before using it, and be sure it is operating properly. Follow the product safety signs, and use any safety features provided.

Case IH is a registered trademark of CNH America LLC.

Any trademarks referred to herein, in association with goods and/or services of companies other than CNH America LLC, are the property of those respective companies.

CNH America LLC reserves the right to make improvements in design and changes in specifications at any time without notice and without incurring any obligation to install them on units previously sold. Specifications, descriptions and illustrative material herein are as accurate as known at time of publication, but are subject to change without notice.

Availability of some models and equipment builds varies according to the country in which the equipment is used.